

**Anritsu** envision : ensure

MP1800A Series

56G/64G bit/s MUX

MP1861A

56G/64G bit/s DEMUX

MP1862A



# Ready for 400G ?



**Computer**

**Server**

SERDES, CDR Chips: CEI-56G-VSR  
Infiniband HDR (50G)  
64G Fibre Channel (56G)  
High-Speed Backplanes and Cables: 400 GbE  
Active Optical Cables (AOC)  
Optical Interconnects

## Developing 400 GbE and CEI-56G

Traffic volumes at data centers are exploding due to the rapid spread of cloud computing services. To increase transmission speeds, standards for new high-speed interfaces like 400 GbE and CEI-56G are being investigated. Assuring signal integrity of PHY devices like SERDES used by these high-speed interfaces is a key requirement in speed increases. Linking the MUX MP1861A and DEMUX MP1862A with the MP1800A with installed 32G PPG/ED and Jitter Modulation Source option supports generation of NRZ Data signals at up to 64.2 Gbit/s, BER measurements and Jitter Tolerance measurements. New standards such as CEI-56G are also supported by Jitter Tolerance measurements of jitter components such as Dual Tone SJ (two different frequencies), RJ, BUJ, SSC, and Half Period Jitter (Even/Odd Jitter) as well as Bathtub Jitter measurements. With its built-in Jitter Tolerance Software for Emphasis and PAM signal generation and Equalizer for correcting the Eye opening, Anritsu's MP1800A is the ideal total solution for signal integrity evaluation.

Optical Transceiver Modules: CDFP  
OTU4 (28Gx4), OTU5  
50Gbaud-QAM for Long Haul  
CEI-56G

**Optical Module**

**Network  
Equipment**



## Anritsu High-Speed Solutions for Every Measurement Need

Wide 56G/64G bit/s bandwidth: Supports CEI-56G, 400 GbE and FEC bit rates

2:1 MUX, 1:2 DEMUX: Expand 28G/32G 2ch BERT to 56G/64G

Compact Remote Head: Cuts losses in DUT connection cable

64.2  
Gbit/s

Wideband Bit Rate  
Up to 64.2 Gbit/s

2:1 MUX  
1:2 DEMUX

Expand 28G/32G 2ch  
BERT to 56G/64G

Compact  
Remote  
Head

Reduces DUT Connection  
Cable Losses

High  
Output  
3.5V  
High  
Sensitivity  
25mV

3.5 Vp-p MUX max.  
x7 Output Variable Range  
25 mV DEMUX Sensitivity

Jitter

Jitter Tolerance Tests  
Bathtub Measurements

Emphasis  
4PAM

Emphasis and 4PAM Signal  
Generation using 2ch Sync  
and Combiner with Rx  
Passive Equalizer

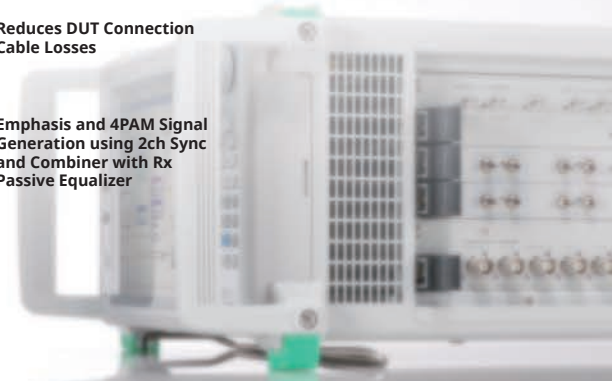

# MP1861/62A

### Excellent Signal Quality and Rx Sensitivity: High-Accuracy Measurement of Semiconductor Chip Characteristics

- ▶ Low Intrinsic Jitter  
RJ = 200 fs rms (typ.)
- ▶ Variable Amplitude  
3.5 Vp-p Output max.
- ▶ High Input Sensitivity  
25 mV  
(typ., Single-ended, Eye Height, 56.2 Gbit/s)

### Versatile Signal Integrity Measurements: Support CEI-56G and 400 GbE Test Requirements

- ▶ TJ/DJ/RJ/Bathtub, Eye Diagram,  
Eye Margin Automatic Measurement
- ▶ Jitter Tolerance Test (using MU181500B)  
Dual Tone SJ (two different frequencies),  
RJ, BUJ, SSC, and Half Period Jitter  
(Even/Odd Jitter)  
Max. SJ Amplitude: 0.55 UI @ fm 250 MHz
- ▶ Crosstalk Test using Independently  
Variable Data skew for Each Channel

### High Expandability: Assured Future-proof Investment

- ▶ Expandable from 32G to 56G/64G BERT  
For 100G/400G R&D
- ▶ Sync Operation for up to 4ch  
Multichannel Sync Pattern  
Generation and Simultaneous  
BER Analysis
- ▶ Emphasis Signal Generation  
(using MZ1854A at 2ch Sync with MP1861A and 57.8 Gbit/s)
- ▶ 4PAM Signal Generation  
(using MZ1854A at 2ch Sync with MP1861A and 56.2 Gbaud)

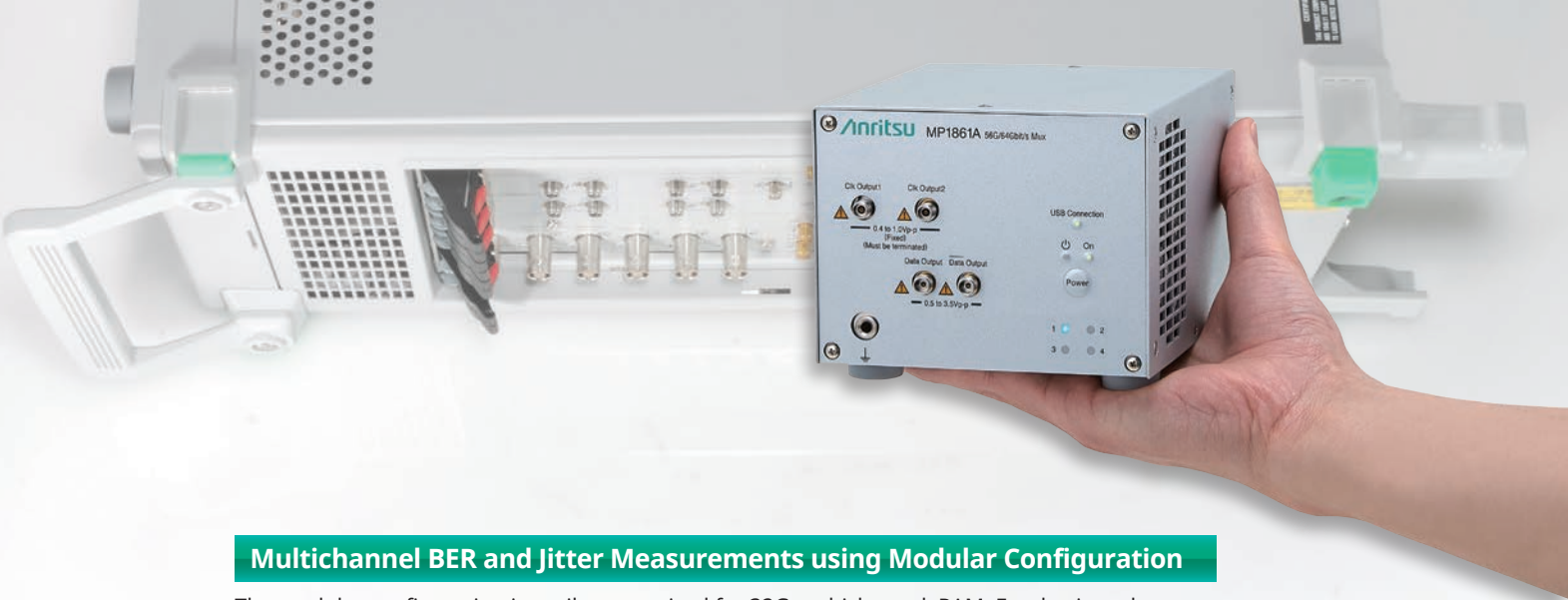

## Multichannel BER and Jitter Measurements using Modular Configuration

The modular configuration is easily customized for 32G multichannel, PAM, Emphasis and 56G/64G serial/multichannel signal analyses and measurements supporting 100G/400G R&D required by new IEEE and OIF standards, helping cut future equipment investment costs.

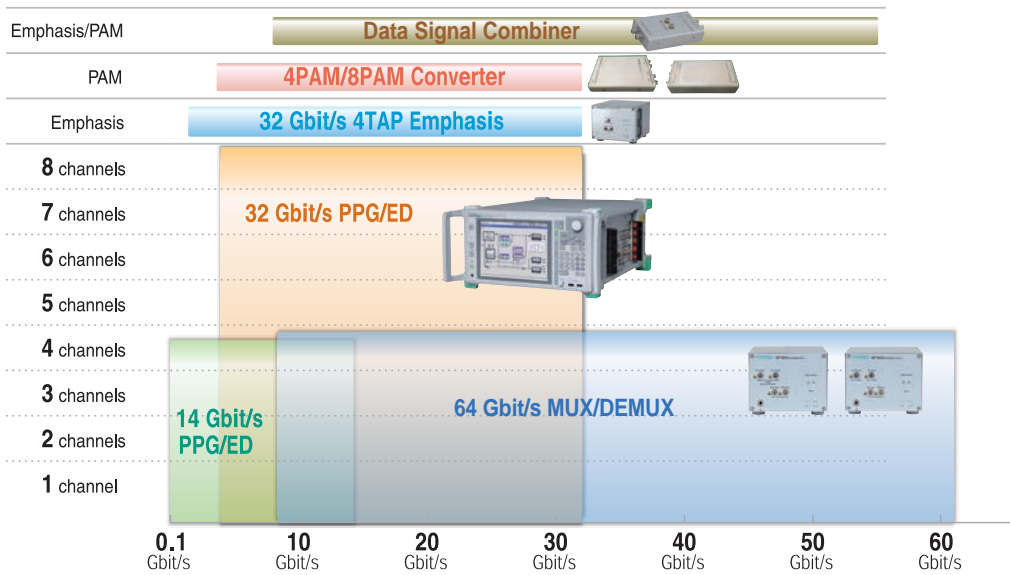

Synchronous operation of up to four MP1800A units generates 64ch × 16G signals.

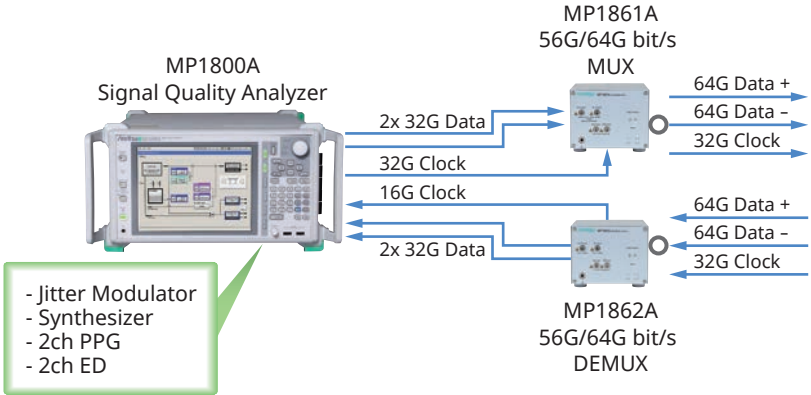

Supports 64G signal quality evaluations using one MP1800A and MUX

# 56G/64G bit/s MUX MP1861A, 56G/64G bit/s DEMUX MP1862A Features

## Low-Jitter and High-Quality Waveform MUX

The MUX MP1861A outputs low-jitter, high-quality waveforms. Various output amplitude options can be selected to match the application.

Low Jitter: RJ = 200 fs rms (typ.)

- Amplitude: 0.5 Vp-p to 2.5 Vp-p ( $\leq 56.2$  Gbit/s, MP1861A-011)
- 1.0 Vp-p to 2.5 Vp-p ( $> 56.2$  Gbit/s, MP1861A-011)
- 0.5 Vp-p to 3.5 Vp-p ( $\leq 56.2$  Gbit/s, MP1861A-013)
- 1.0 Vp-p to 3.5 Vp-p ( $> 56.2$  Gbit/s, MP1861A-013)

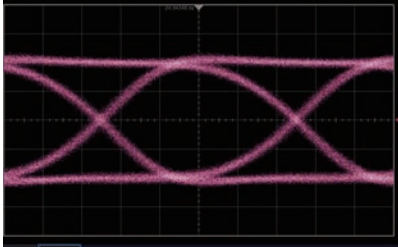

Output Waveform at 50 Gbit/s and 3.5 Vp-p (MP1861A-013)

## High-Sensitivity DEMUX

The DEMUX MP1862A has high sensitivity to support various applications up to 64 Gbit/s.

Sensitivity: 25 mV (typ.)

$\leq 40$  mV (Eye Height, PRBS31, Single-ended, 56.2 Gbit/s)

## SJ, RJ, BUJ, SSC and Half Period Jitter (F/2 Jitter) Generation

The Jitter Modulator MU181500B generates wide-amplitude SJ up to 0.55 UI at a Jitter Frequency of 250 MHz and a maximum 2000 UI, ensuring sufficient margin for receiver Jitter Tolerance tests. Additionally, the Intrinsic Jitter of 275 fs rms (nominal)\* is extremely low, not only when Jitter modulation is OFF but also when 0 UI is set at Jitter modulation ON, ensuring accurate measurements even at low Jitter amplitudes.

The combination of low intrinsic jitter waveform with excellent jitter transparency supports high-accuracy Jitter Tolerance tests. Moreover, simultaneous injection of RJ, BUJ and SSC as well as dual SJ for two-tone supports various Jitter Tolerance tests. Additionally, the Jitter/Noise Tolerance Test Software MX181500A supports multi-mask tables as well as easy mask editing to support next-generation standards.

\*: Phase noise measurement with using Spectrum Analyzer and 1010... repetition signal.

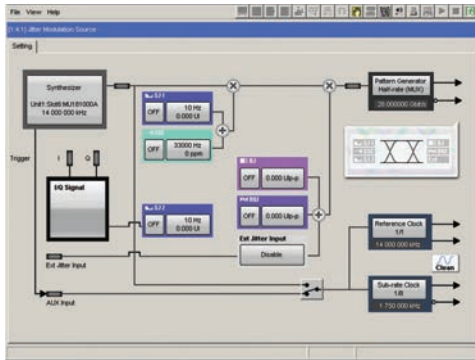

Jitter Modulation Source MU181500B Setting Screen

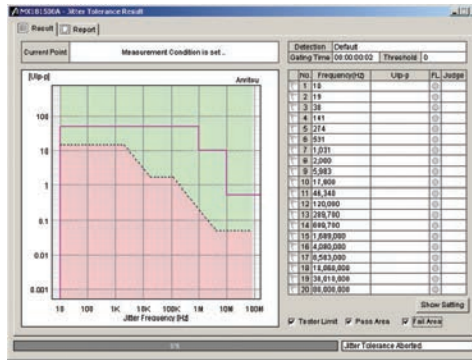

Jitter/Noise Tolerance Test Software MX181500A Setting Screen

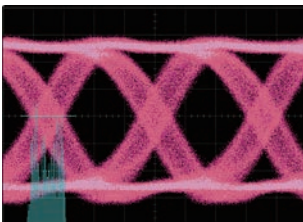

Sinusoidal Jitter (SJ)

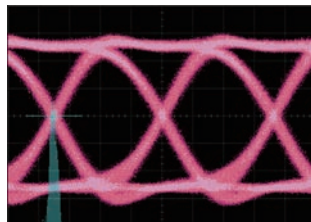

Random Jitter (RJ)

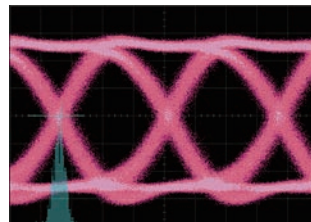

Bounded Uncorrelated Jitter (BUJ)

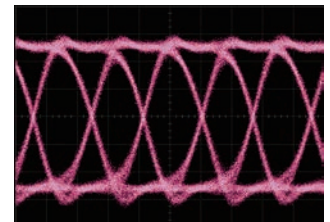

Half Period Jitter (F/2 Jitter)

# 56G/64G bit/s MUX MP1861A, 56G/64G bit/s DEMUX MP1862A Features

## Emphasis Signal Generation

Linking two MUXes MP1861A using the Data Signal Combiner MZ1854A supports generation of a 2Tap Emphasis signal at up to 57.8 Gbit/s. Since the MP1800A external Remote Head can get close to the DUT, the effect of cable losses is minimized to assure high signal quality is maintained. Accurate Jitter Tolerance tests are possible using the pre-Emphasis signal supporting transmission path loss required by CEI-56G.

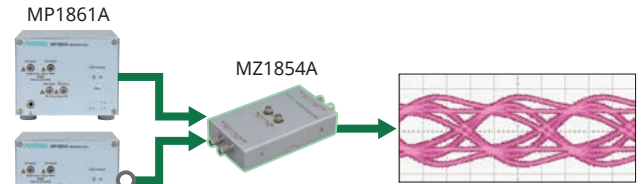

Generation using 2ch Sync, 1-bit delay and inverse addition Emphasis waveform

## 4PAM Signal Generation

Linking two MUXes MP1861A using the Data Signal Combiner MZ1854A supports generation of 4PAM signals up to 56.2 Gbaud. Using the MP1861A high-quality NRZ waveform with a wideband passive combiner supports generation of the PAM signals required for R&D into high-speed backplanes and high-speed optical modulation.

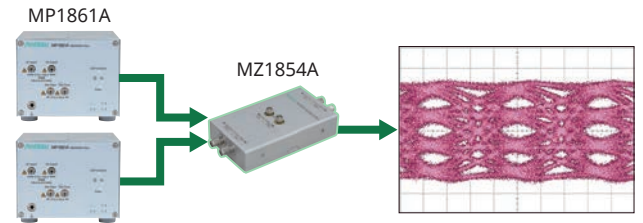

4PAM Waveform generation using 2 ch Sync, any bit delay and addition

## Passive Equalizer

High-speed serial transmissions such as 56 Gbit/s suffer from a closed Eye opening due to losses in the transmission path. Inserting the Passive Equalizer J1646A upstream of the DEMUX MP1862A compensates for transmission path losses and restores the Eye opening. Combination with the high-sensitivity DEMUX MP1862A supports BER measurements and Jitter Tolerance tests of PHY devices with a closed Eye opening.



Eye Opening using Passive Equalizer

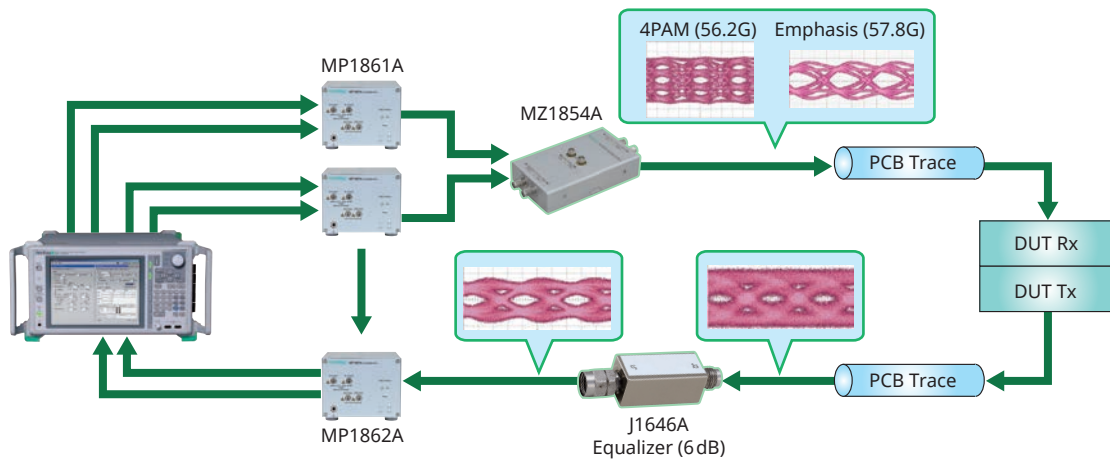

Measurement System using MP1861A, MP1862A, MZ1854A and J1646A



# 56G/64G bit/s MUX MP1861A, 56G/64G bit/s DEMUX MP1862A Features

## Bathtub Jitter

Measures optimum bit error rate based on changes in bit error rate relative to phase margin and performs jitter analysis (TJ, DJ, RJ).

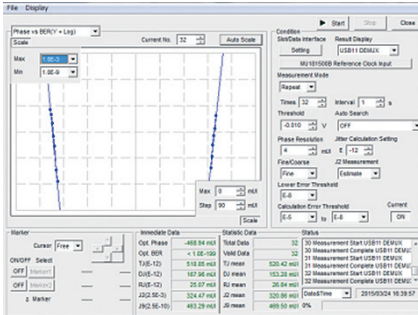

## Eye Diagram

Captures bit error rate contours linking specified bit error rate points.

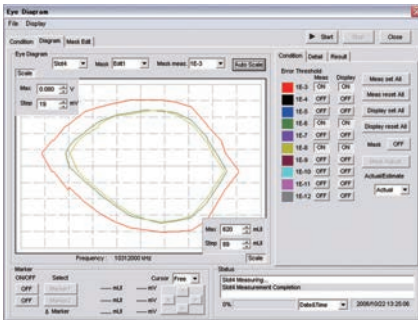

## Eye Margin

Confirms Data threshold and phase margins.

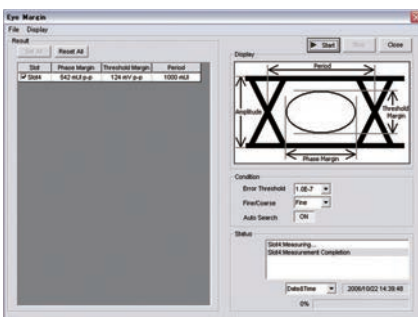

## Crosstalk Tests

Independently controls phase for each channel using built-in PPG Data Delay option to examine DUT crosstalk characteristics with excellent accuracy in 4-mUI steps.

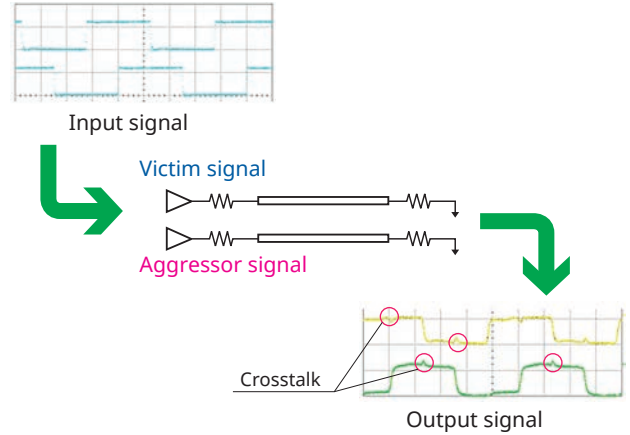

## Up to 4ch Sync

Using an external MUX and DEMUX supports syncing for up to 4ch by connecting to the PPG and ED modules installed in the MP1800A. D/A converter, crosstalk and skew tolerance tests are all supported.

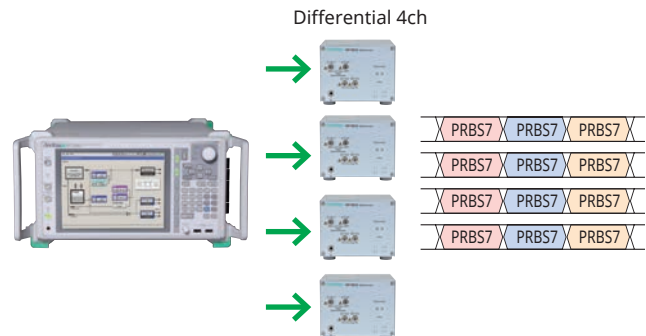

## Versatile Pattern Generation

### • Pseudorandom Patterns (PRBS)

All PRBS patterns required by standards are supported up to PRBS  $2^{31} - 1$ .

$$2^n - 1 \quad (n = 7, 9, 10, 11, 15, 20, 23, 31)$$

### • Zero Substitution Pattern

Consecutive 0s and 1s patterns can be added to PRBS patterns for Clock Data Recovery (CDR) tolerance tests.

$$2^n, 2^n - 1 \quad (n = 7, 9, 10, 11, 15, 20, 23)$$

### • Data Pattern

Patterns required by each application, such as CJTPAT, CJPAT, K28.5 and 4PAM PRBS can be created flexibly.

512 Mbits/ch max. (Steps: 2 bit)

### • Mixed Pattern

A mixed data and PRBS pattern can be output. At creation of SONET/SDH frames, adding a PRBS  $2^{31} - 1$ , etc., pattern to the payload supports setting of a continuous pattern across frames.

### • Burst Signals

Application evaluation using burst signals, such as optical loop test and transmission test using quantum noise technology are supported.

# 56G/64G bit/s MUX MP1861A, 56G/64G bit/s DEMUX MP1862A Features

## Applications

### Measuring 56-Gbit/s Band High-Speed Semiconductor Chips

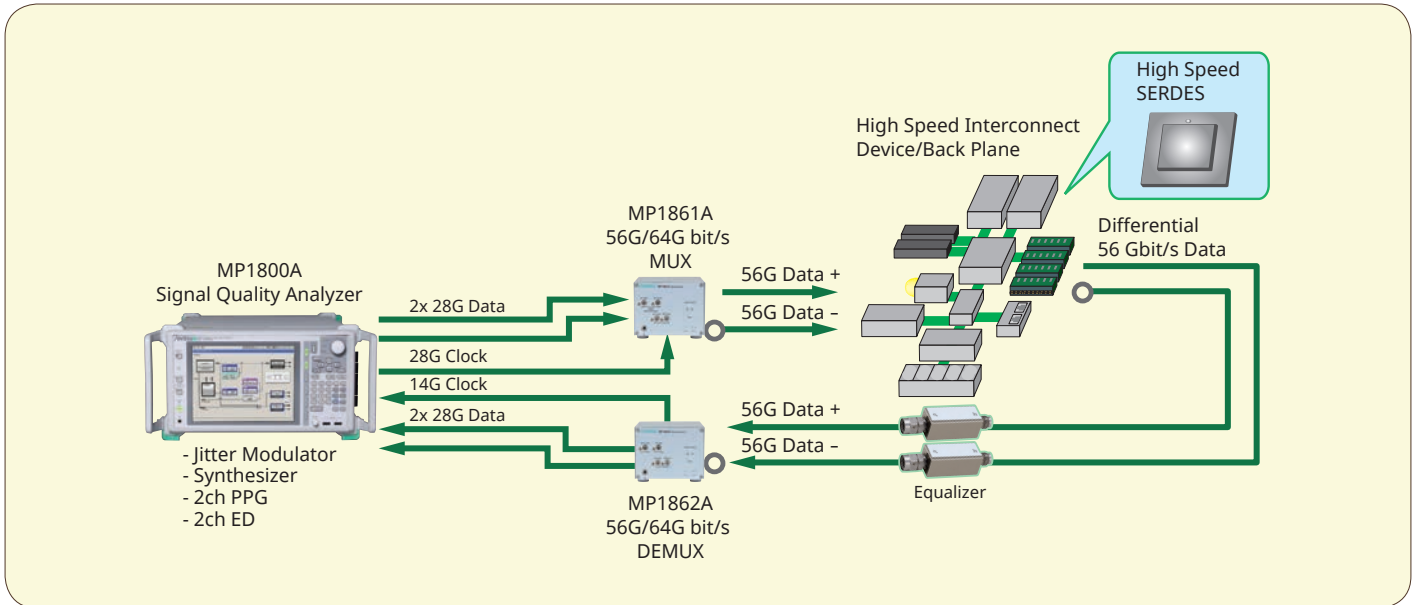

### Test Requirements

- 56 Gbit/s BER Measurements
- Jitter Tolerance Measurements
- Input Sensitivity Test
- Bathtub Jitter Measurements

### 56 Gbit/s BER Measurements

The bit rates of high-performance servers, switch backplanes, etc., are becoming increasingly faster while consuming less power. Evaluation of signal integrity is important for evaluating dropping input/output amplitudes of semiconductor chips such as SERDES and CDR to reduce power consumption. The signal output of these low-amplitude devices can be received securely using the high-sensitivity performance 25 mV (typ.) of the DEMUX MP1862A.

### Input Sensitivity Tests

With a wide tuning range of 0.5 Vp-p to 3.5 Vp-p max., the MUX MP1861A supports device input sensitivity tests (when 56 Gbit MP1861A-013 installed.) The MP1861A incorporates a 6-dB ATT as standard for use over a range of 0.25 Vp-p to 1.75 Vp-p. Anritsu recommends using a 6-dB ATT to prevent risk of damage from EOS (Electric Over Stress).

### Jitter Tolerance Tests

Installing the Jitter Modulation Source MU181500B in the MP1800A supports independent and simultaneous injection of Dual SJ (two types), RJ, BUJ, and SSC jitter components for Jitter Tolerance tests meeting various standards, such as CEI-56G, etc.

### Bathtub Jitter Measurement

Standards such as CEI-56G specify device output Jitter Tolerance values.

Bathtub Jitter measurement analyzes the device Total Jitter (TJ) and RJ and DJ components from changes in the bit error rate with phase. It also calculates the optimum bit error rate. A clean Clock reference signal is required by the DEMUX and ED at Bathtub Jitter measurement. The MP1862A supports Bathtub Jitter measurement using a clean Clock with jitter addition.



# 56G/64G bit/s MUX MP1861A, 56G/64G bit/s DEMUX MP1862A Features

## Applications (continued)

### Evaluating 400 GbE Transmitters

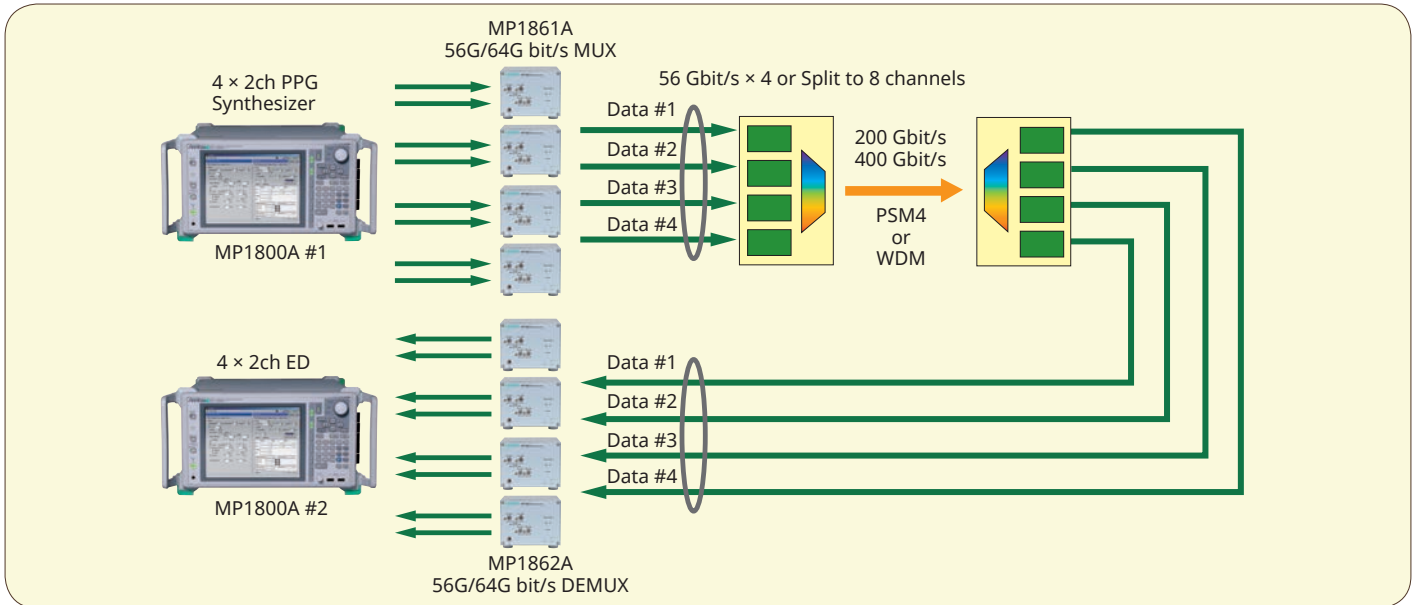

### Test Requirements

- 4ch Simultaneous BER Measurement
- Optimized Optical Output Waveform using Crosspoint Adjustment
- Lane Timing and Skew Control
- Input Sensitivity Tests

### Evaluating 400 GbE and 56G × 4 Lane Systems

By using a MUX/DEMUX supporting bit rates up to 56 Gbit/s, it is possible to evaluate 400 GbE EML and optical modules using 4ch synchronous operation now being investigated by IEEE 802.3 bs.

### Ideal Signal Quality for EML Evaluations

With a tunable output function of up to 3.5 Vp-p, EMLs can be driven directly. The amplitude and crosspoint can be adjusted easily on the screen to shorten evaluation times and offer high-reliability evaluations.

### Confirming Skew and Crosstalk Effects

Applications using 56-Gbit/s class signals require both theoretical and practical verifications. Since the MP1800A supports pattern synchronization and has a phase tuning function, it is the ideal instrument for easy examination of Rx device skew tolerance, crosstalk effects, etc.

### Built-in High-Sensitivity Auto-Search Function

The built-in DEMUX MP1862A Auto Search function supports auto-tuning of the Data and Clock phase difference as well as optimization of the voltage threshold value. It is possible to easy operation for optical receiver sensitivity tests.

# 56G/64G bit/s MUX MP1861A, 56G/64G bit/s DEMUX MP1862A Features

## Applications (continued)

### AOC/Backplane Device Stress Jitter Tolerance Test

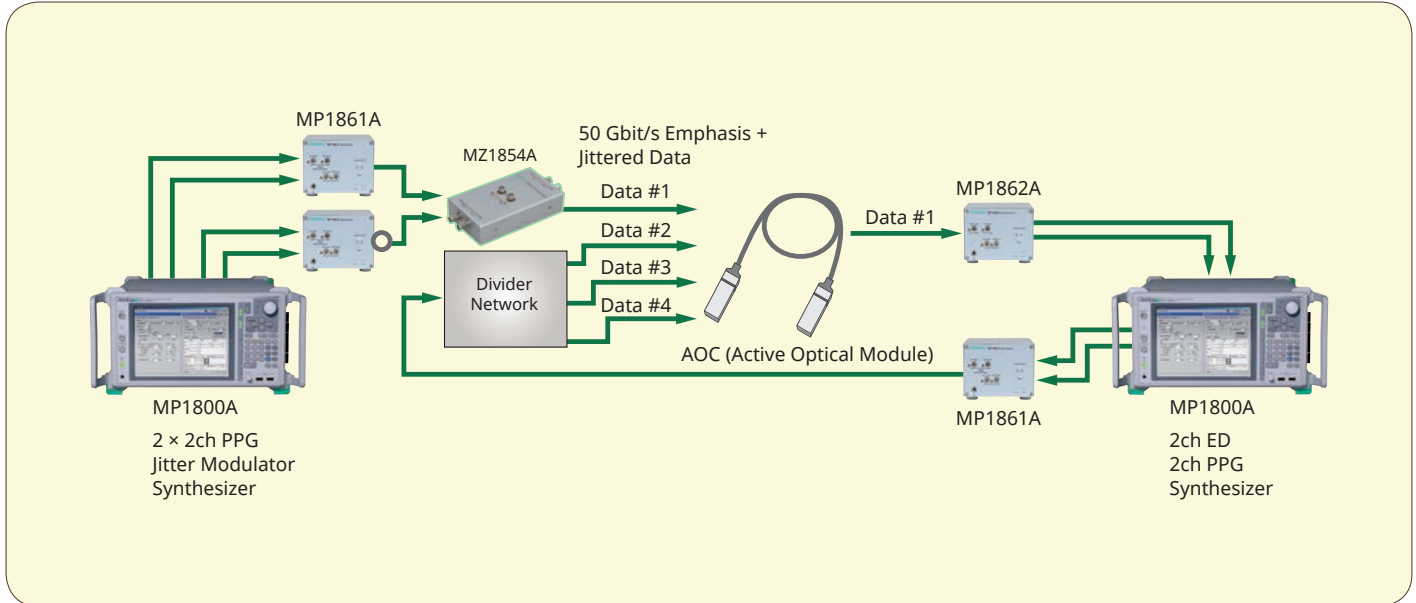

### Test Requirements

- Emphasis Signal Generation
- Crosstalk Test
- Jitter Tolerance Test
- Bathtub Jitter and Eye Diagram Analyses

### Generating Emphasis

Emphasis signals can be generated using the MP1861A 2ch synchronization function and Data Signal Combiner MZ1854A to compensate for transmission path losses at the electrical interface of Active Optical Cables (AOC) and Backplane devices and recover the Eye opening.

### Jitter Tolerance Tests

The Jitter Modulation Source MU181500B injects SJ (two types), RJ, BUJ, and SSC simultaneously or independently for Jitter Tolerance tests meeting various standards.

### Confirming Crosstalk Effects

Processing of 56-Gbit/s class signals requires both theoretical and practical verification. With its pattern synchronization and independent phase tuning function for each channel, the MP1800A makes it easy to examine AOC and Backplane crosstalk effects, etc.

### Bathtub and Eye Diagram Analyses

Bathtub Jitter analysis (TJ, RJ, DJ components) is performed using the Clock Delay function of the built-in ED. Even low bit-error rates, such as 1E-12 and 1E-15, can be estimated quickly from changes in the bit error rate with phase.

# 56G/64G bit/s MUX MP1861A, 56G/64G bit/s DEMUX MP1862A Panel Layout

## 56G/64G bit/s MUX MP1861A Front Panel

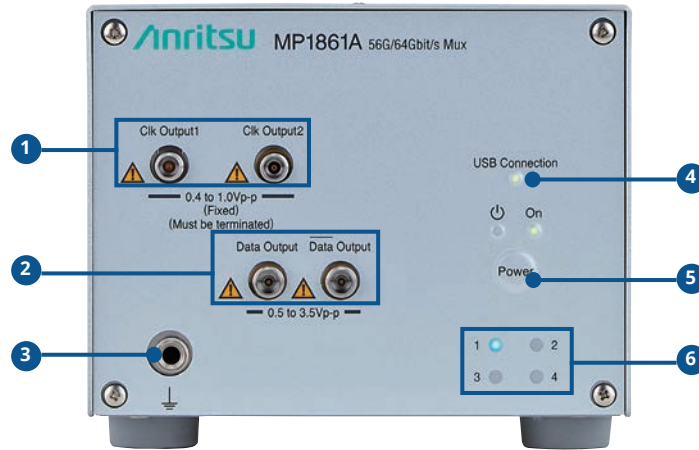

1	Clock Output 1 Connector Clock Output 2 Connector	Outputs Clock reference for DUT and MP1862A
2	Data Output Connector Data Output Connector	Output 2:1 MUXed differential Data signals
3	Ground Jack	Grounds connected wrist strap and Ground on a DUT to discharge static charges
4	USB Connection LED	Indicates connection status with MP1800A or PC controller
5	Power Switch	Switches power between on and standby
6	Channel LEDs	Indicate channel numbers

## Rear Panel



1	DC Input Connector	Connects to AC adapter
2	Ext. Clock Input Connector	Inputs Clock reference signal for this instrument
3	Ground Jack	Grounds connected wrist strap and Ground on a DUT to discharge static charges
4	Data Input 1 Connector Data Input 2 Connector	Inputs Data signal from MU18302xA
5	1/2 Clock Output Connector	Outputs 1/2 frequency divided Clock of Clock input to Ext. Clock Input connector
6	USB Port	Connects MP1800A or PC to this instrument
7	Buffered Clock Output Connector	Outputs same Clock frequency as Clock input to Ext. Clock Input connector
8	Channel Setting Switch	Sets instrument channel number
9	Mux Clock Input Connector	For input of Clock with same frequency as Clock input to Ext. Clock input connector
10	Delayed Clock Output Connector	Outputs Clock with same frequency as Clock input to Ext. Clock input connector



# 56G/64G bit/s MUX MP1861A, 56G/64G bit/s DEMUX MP1862A Panel Layout

## 56G/64G bit/s DEMUX MP1862A Front Panel

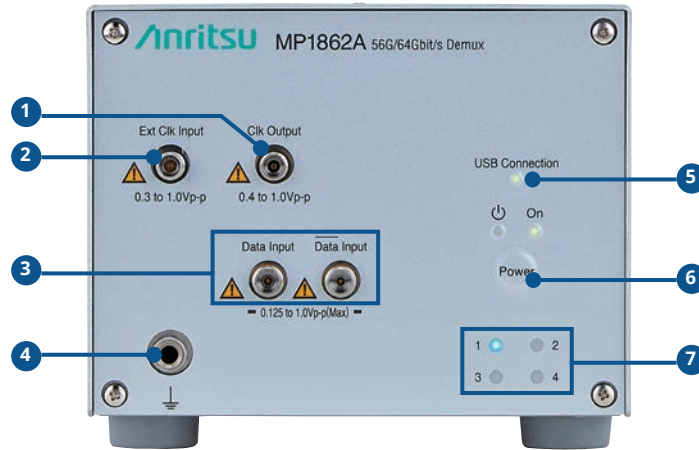

1	Clock Output Connector	Outputs same Clock frequency as Clock input to Ext. Clock Input connector
2	Ext. Clock Input Connector	Inputs Clock reference signal for this instrument
3	Data Input Connector Data Input Connector	Inputs differential data signal
4	Ground Jack	Grounds connected wrist strap and Ground on a DUT to discharge static charges
5	USB Connection LED	Indicates connection status with MP1800A or PC controller
6	Power Switch	Switches power between on and standby
7	Channel LEDs	Indicate channel numbers

## Rear Panel

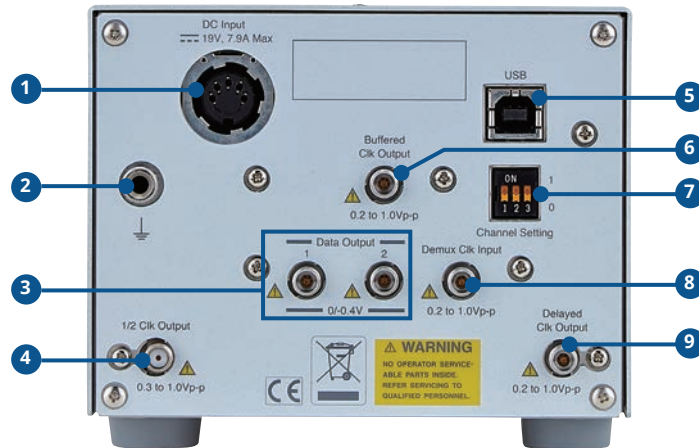

1	DC Input Connector	Connects to AC adapter
2	Ground Jack	Grounds connected wrist strap and Ground on a DUT to discharge static charges
3	Data Output 1 Connector Data Output 2 Connector	Outputs 1:2 divided Data/Input signal. Outputs Data signal to MU18304x/A/B
4	1/2 Clock Output Connector	Outputs 1/2 frequency divided Clock of Clock input to Ext. Clock Input connector. Outputs Clock signal to MU18304x/A/B
5	USB Port	Connects MP1800A or PC to this instrument
6	Buffered Clock Output Connector	Outputs same Clock frequency as Clock input to Ext. Clock Input connector
7	Channel Setting Switch	Sets instrument channel number
8	Demux Clock Input Connector	For input of same frequency as Clock input to Ext. Clock input connector when necessary
9	Delayed Clock Output Connector	Outputs Clock with same frequency as Clock input to Ext. Clock input connector

## 56G/64G bit/s MUX MP1861A, 56G/64G bit/s DEMUX MP1862A Selection Guide

Category	Model Number	Model Name	56G 1ch Basic	64G 1ch Basic	High-Speed Semiconductor Chips	400G Modules	AOC Back Planes	Emphasis/ 4PAM
56G/64G MUX	MP1861A	56G/64G bit/s MUX	1	1	1	4	3	2
	MP1861A-001	64G bit/s Extension	-	1	-	-	-	2
	MP1861A-011	Variable Data Output (0.5 to 2.5 Vp-p)	1*1	1*1	1*1	4*1	3*1	2*1
	MP1861A-013	Variable Data Output (0.5 to 3.5 Vp-p)						
	MP1861A-030	Variable Data Delay	-	-	1	4	3	2
56G/64G DEMUX	MP1862A	56G/64G bit/s DEMUX	1	1	1	4	1	2
	MP1862A-001	64G bit/s Extension	-	1	-	-	-	2
Main Frame	MP1800A	Signal Quality Analyzer	1	1	1	2	2	2
	MP1800A-014	2-Slot for PPG and/or ED	1	1	1*1	-	-	2*1
	MP1800A-015	4-Slot for PPG and/or ED	-	-		2*1	2*1	
	MP1800A-016	6-Slot for PPG and/or ED	-	-				
	MP1800A-032	32 Gbit/s PPG and/or ED Support	1	1	1	2	2	2
Synthesizer (Sinusoidal Jitter)	MU181000A	12.5 GHz Synthesizer	1	1	1	-	-	-
	MU181000A-001	Jitter Modulation	-	-	1	-	-	-
Synthesizer (Sinusoidal Jitter)	MU181000B	12.5 GHz 4port Synthesizer	-	-	-	1	1	1
	MU181000B-001	Jitter Modulation	-	-	-	-	1	-
Jitter Modulator SJ (2-tone)/RJ/BUJ	MU181500B	Jitter Modulation Source	-	-	1	-	1	1
28G/32G PPG 2ch	MU183020A	28G/32G bit/s PPG	1	1	1	4	3	2
	MU183020A-001	32G bit/s Extension	-	1	-	-	-	2
	MU183020A-022	2ch 2 V Data Output	1	1	1	4	3	2
	MU183020A-023	2ch 3.5 V Data Output	-	-	-	-	-	-
	MU183020A-031	2ch Data Delay*2	1	1	1	4	-	2
28G/32G ED 2ch	MU183040B	28G/32G bit/s High Sensitivity ED	1	1	1	4	1	2
	MU183040B-001	32G bit/s Extension	-	1	-	-	-	2
	MU183040B-020	2ch ED	1	1	1	4	1	2
Combiner	MZ1854A	Data Signal Combiner	-	-	-	-	1	1
Software	MX181500A	Jitter/Noise Tolerance Test Software	-	-	1	-	1	1

\*1: Select any one

\*2: Required when using 56G/64G bit/s MUX MP1861A

# 56G/64G bit/s MUX MP1861A, 56G/64G bit/s DEMUX MP1862A Specifications

## 56G/64G bit/s MUX MP1861A

Operational Bit-rate Range	8 Gbit/s to 56.2 Gbit/s 8 Gbit/s to 64.2 Gbit/s (with Option 01 installed)	
External Clock Input (Half-rate Clock Input)	Number of Input: 1 Frequency: 4 GHz to 28.1 GHz 4 GHz to 32.1 GHz (with Option 01 installed) Amplitude: 0.3 Vp-p to 1.0 Vp-p Termination: 50Ω/AC Coupling Connector: K (f)	
Data Input	Number of Input: 2 (Data Input1, Data Input2) Input level: 0/-0.7 V (H: -0.15 to +0.05, L: -0.85 to -0.55) Termination: 50Ω/GND Connector: K (f)	
1/2 Clock Output	Number of Output: 1 Frequency: 2 GHz to 14.05 GHz 2 GHz to 16.05 GHz (with Option 01 installed) Output amplitude: 0.3 Vp-p to 1.0 Vp-p Termination: 50Ω/AC Coupling Connector: SMA (f)	
Clock Output 1, 2	Number of Output: 2 (Clock Output1, Clock Output2) Frequency: 4 GHz to 28.1 GHz 4 GHz to 32.1 GHz (with Option 01 installed) Output amplitude: 0.4 Vp-p to 1.0 Vp-p Termination: 50Ω/AC Coupling Connector: K (f)	
Buffered Clock Output	Number of Output: 1 Frequency: 4 GHz to 28.1 GHz 4 GHz to 32.1 GHz (with Option 01 installed) Output amplitude: 0.2 Vp-p to 1.0 Vp-p Termination: 50Ω/AC Coupling Connector: K (f)	
Delayed Clock Output	Number of Output: 1 Frequency: 4 GHz to 28.1 GHz 4 GHz to 32.1 GHz (with Option 01 installed) Output amplitude: 0.2 Vp-p to 1.0 Vp-p Termination: 50Ω/AC Coupling Connector: K (f)	
MUX Clock Input	Number of Input: 1 Frequency: 4 GHz to 28.1 GHz 4 GHz to 32.1 GHz (with Option 01 installed) Amplitude: 0.2 Vp-p to 1.0 Vp-p Termination: 50Ω/AC Coupling Connector: K (f)	
Data Output*1	Option x11	Option x13
	Number of Output: 2 (Data Output/ Data Output)	
	Amplitude: 0.5 Vp-p to 2.5 Vp-p/2 mV Step (@≤56.2 Gbit/s) 1.0 Vp-p to 2.5 Vp-p/2 mV Step (@>56.2 Gbit/s)	Amplitude: 0.5 Vp-p to 3.5 Vp-p/2 mV Step (@≤56.2 Gbit/s) 1.0 Vp-p to 3.5 Vp-p/2 mV Step (@>56.2 Gbit/s)
	Setting Error: ±50 mV ±17% of Amplitude*2, *3, *4 Offset: -2.0 to +3.3 Voh/1-mV Step, min.: -4.0 Vol Setting Error: ±65 mV ±10% of Offset (Vth) ± (Output amplitude setting error/2) Current Limit: Source 100 mA/Sink 100 mA Crosspoint: 45 to 55%/0.1% Step (≤56.2 Gbit/s) >56.2 Gbit/s, with MP1861A-x 01 installed: Since >50% is not assured, displays Overload	
	Tr/Tf: Typ. 8 ps (20 to 80%)*2, *3, *4 Half Period Jitter: -20 to 20/1 Step Jitter (rms): 450 fs typ., ≤550 fs*2, *4, *5 Jitter (rms): 650 fs typ.*3, *4, *5 Random Jitter (rms): 200 fs typ.*2, *4, *5 Waveform Distortion (0-peak): ±25 mV ±10% of Amplitude typ.*2, *3, *4, *6 ON/OFF Output Switch Function Termination: AC/DC switchable, 50Ω/GND, -2 V, +1.3 V (at DC selection) Connector: V (f)	



## 56G/64G bit/s MUX MP1861A, 56G/64G bit/s DEMUX MP1862A Specifications

Jitter Tolerance	<p>56.2 Gbit/s, 64.2 Gbit/s (with Option 01 installed), at PRBS 2<sup>31</sup> - 1, Mark ratio 1/2, Crosspoint 50%, MP1861A - MP1862A Loopback, Temperature: +20° to +30°C 56.2 Gbit/s up to 250 MHz modulation frequency; 64.2 Gbit/s up to 150 MHz modulation frequency</p> <p>The graph plots Jitter Amplitude [UIp-p] on the y-axis against Modulation Frequency [MHz] on the x-axis. The y-axis has major ticks at 0.55, 10, 15, and 2000. The x-axis has major ticks at 0.00001, 0.0075, 1, 10, 150, and 250. The curve starts at a jitter amplitude of 2000 UIp-p for frequencies up to 0.0075 MHz. From 0.0075 MHz to 1 MHz, the jitter amplitude decreases linearly on a log-log scale with a slope of 20 dB/decade. At 1 MHz, the jitter amplitude is 15 UIp-p. At 10 MHz, it is 10 UIp-p. At 150 MHz, it reaches 0.55 UIp-p and remains constant up to 250 MHz.</p>
Variable Data Delay	Variable Phase Range: -64000 mUI to +64000 mUI/4 mUI Step Phase Setting Error: ±50 mUIp-p typ.*5
Control Interface	USB 2.0 or 1.1 Type B × 1
Channel Setting	1ch to 4ch Selectable
Power Supply (AC adapter)	Input Voltage: 100 V(ac) to 240 V(ac)*7 Input Frequency: 50 Hz to 60 Hz Output power: 19 V(dc), 7.9 A (max.)
Power Consumption	19 V(dc), 4 A
Dimensions and Mass	120 (W) × 90.9 (H) × 140 (D) mm (Excluding protrusions), ≤5 kg
Temperature	Operation: +15° to +35°C (with options installed) Storage: -20° to +60°C

- \*1: Unless otherwise described, at PRBS 2<sup>31</sup> - 1, Mark Ratio 1/2. Values observed using Coaxial Cable J1656A and 70-GHz band sampling oscilloscope
- \*2: At 56.2 Gbit/s
- \*3: 64.2 Gbit/s (with MP1861A Option x01 installed)
- \*4: Crosspoint: 50%
- \*5: Jitter Standard values when oscilloscope intrinsic jitter ≤200 fs
- \*6: Output Amplitude: 2.5 Vp-p
- \*7: Operation voltage: +10% and -15% of specified voltage

# 56G/64G bit/s MUX MP1861A, 56G/64G bit/s DEMUX MP1862A Specifications

## 56G/64G bit/s DEMUX MP1862A

Operational Bit-rate Range	8 Gbit/s to 56.2 Gbit/s 8 Gbit/s to 64.2 Gbit/s (with Option 01 installed)
External Clock Input (Half-rate Clock Input)	Number of Input: 1 Frequency: 4 GHz to 28.1 GHz 4 GHz to 32.1 GHz (with Option 01 installed) Amplitude: 0.3 Vp-p to 1.0 Vp-p Termination: 50Ω/AC Coupling Connector: K (f)
Data Output	Number of Output: 2 (Data Output1, Data Output2) Output Level: 0/-0.4 V (H: -0.1 to +0.1, L: -0.6 to -0.3) Termination: 50Ω/GND Connector: K (f)
1/2 Clock Output	Number of Output: 1 Frequency: 2 GHz to 14.05 GHz 2 GHz to 16.05 GHz (with Option 01 installed) Output amplitude: 0.3 Vp-p to 1.0 Vp-p Termination: 50Ω/AC Coupling Connector: SMA (f)
Clock Output	Number of Output: 1 Frequency: 4 GHz to 28.1 GHz 4 GHz to 32.1 GHz (with Option 01 installed) Output amplitude: 0.4 Vp-p to 1.0 Vp-p Termination: 50Ω/AC Coupling Connector: K (f)
Buffered Clock Output	Number of Output: 1 Frequency: 4 GHz to 28.1 GHz 4 GHz to 32.1 GHz (with Option 01 installed) Output amplitude: 0.2 Vp-p to 1.0 Vp-p Termination: 50Ω/AC Coupling Connector: K (f)
Delayed Clock Output	Number of Output: 1 Frequency: 4 GHz to 28.1 GHz 4 GHz to 32.1 GHz (with Option 01 installed) Output amplitude: 0.2 Vp-p to 1.0 Vp-p Termination: 50Ω/AC Coupling Connector: K (f)
DEMUX Clock Input	Number of Input: 1 Frequency: 4 GHz to 28.1 GHz 4 GHz to 32.1 GHz (with Option 01 installed) Amplitude: 0.2 Vp-p to 1.0 Vp-p Termination: 50Ω/AC Coupling Connector: K (f)
Data Input	Number of Input: 2 (Data Input/ $\overline{\text{Data Input}}$ ), Differential Amplifier: Single-ended, 50Ω, Differential 50Ω, Differential 100Ω selectable Data, XData selectable Tracking, Independent, Alternate selectable At Alternate setting: Data-XData, XData-Data selectable (Absolute value of Data, XData Threshold Difference: 3.0 V max.) Input Data Format: NRZ Amplitude: 0.125 Vp-p to 1.0 Vp-p*1, *2 Threshold Voltage: -3.5 V to +3.3 V/1-mV step (independently settable Data, selectable. Absolute value of Data, XData Threshold Difference: 3.0 V max.) Input Sensitivity: 25 mV typ., ≤40 mV*1, *3, *4, *5 30 mV typ.*1, *4, *5, *6 Phase Margin: 200° typ.*3, *6, *7 Termination: 50Ω/GND, Variable Termination Voltage: -2.5 V to +3.5 V/0.01-V step at Variable setting Connector: V (f)

# 56G/64G bit/s MUX MP1861A, 56G/64G bit/s DEMUX MP1862A Specifications

Jitter Tolerance	<p>56.2 Gbit/s, 64.2 Gbit/s (with Option 01 installed), PRBS 2<sup>31</sup> - 1, Mark ratio 1/2, Crosspoint 50%, MP1861A - MP1862A Loopback, Temperature: +20° to +30°C 56.2 Gbit/s up to 250 MHz modulation frequency; 64.2 Gbit/s up to 150 MHz modulation frequency</p> <p>The graph plots Jitter Amplitude [UIp-p] on the y-axis (log scale: 0.55, 10, 15, 2000) against Modulation Frequency [MHz] on the x-axis (log scale: 0.00001, 0.0075, 1, 10, 150, 250). A red line shows the tolerance, which is constant at 2000 UIp-p until 0.0075 MHz, then slopes downward at 20 dB/decade, crossing 15 UIp-p at 1 MHz and 0.55 UIp-p at 250 MHz.</p>
Variable Clock Phase	Variable Phase Range: -1000 mUI to +1000 mUI/4 mUI Step Phase Setting Error: ±50 mUIp-p typ.*8
Automatic Measurement	Auto Search, Eye Margin, Eye Diagram, Bathtub
BER Measurement Result Display	With indication screens
Control Interface	USB 2.0 or 1.1 Type B × 1
Channel Setting	1ch to 4ch Selectable
Power Supply (AC adapter)	Input Voltage: 100 V(ac) to 240 V(ac)*9 Input Frequency: 50 Hz to 60 Hz Output power: 19 V(dc), 7.9 A (max.)
Power Consumption	19 V(dc), 4 A
Dimensions and Mass	120 (W) × 90.9 (H) × 140 (D) mm (Excluding protrusions), ≤5 kg
Temperature	Operation: +15° to +35°C (with options installed) Storage: -20° to +60°C

\*1: At single-ended, 50Ω

\*2: Amplitude range using Auto Search and Auto Measurement functions. Sensitivity at minimum error-free input amplitude.

\*3: At 56.2 Gbit/s

\*4: At PRBS 2<sup>31</sup> - 1, Mark Ratio 1 / 2, +20° to +30°C, using Coaxial Cable J1656A

\*5: Standard at Eye Height. Using the measurement system shown in the following diagram (output amplitude monitored using sampling oscilloscope with bandwidth of better than 70 GHz and intrinsic jitter of less than 200 fs), Eye Height (total measurement count of 30) is the value of the amplitude measured by the oscilloscope when the BER becomes 1E-9 when the amplitude is decreased using the MP1861A + ATT.

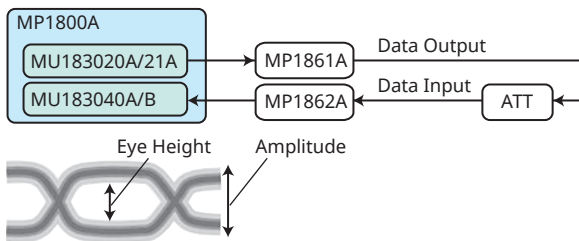

\*6: 64.2 Gbit/s (with MP1862A Option x01 installed)

\*7: Standard with Tx intrinsic jitter component deducted

\*8: Jitter standard value when oscilloscope intrinsic jitter ≤200 fs

\*9: Operation voltage: +10% and -15% of specified voltage



## 56G/64G bit/s MUX MP1861A, 56G/64G bit/s DEMUX MP1862A Specifications

### Data Signal Combiner MZ1854A

Data Output	Number of Output: 2 (Data, XData) Output Amplitude*1: 0.238 Vp-p to 0.594 Vp-p (with using MP1861A-011) 0.238 Vp-p to 0.832 Vp-p (with using MP1861A-013) Connector: V (f)
Data Input	Number of Input: 4 (Data1, XData1, Data2, XData2) Input Amplitude: 0.5 Vp-p to 3.5 Vp-p Connector: V (m)
Insertion Loss	-16 dBm (nominal)*2
General	Temperature Operation: +15° to +35°C Storage: -20° to +60°C Dimensions and Mass: 60.2 (W) × 104.7 (H) × 23.5 (D) mm (Excluding protrusions), ≤2 kg

\*1: Level 0 to 3

\*2: Data\_n input to Data output

### Passive Equalizer 6 dB (V connector) J1646A

Frequency Range	DC to 28 GHz (56 Gbit/s band)
Slope	6.0 dB ±1.0 dB
Insertion Loss	At 28 GHz ≤2.8 dB
Return Loss	11 dB (min.)
General	Connector: V Impedance: 50Ω Dimensions: 44 (W) × 12 (H) × 11 (D) mm

## Ordering Information

### 56G/64G bit/s MUX MP1861A, 56G/64G bit/s DEMUX MP1862A

Please specify the model/order number, name and quantity when ordering.  
The names listed in the chart below are Order Names. The actual name of the item may differ from the Order Name.

#### 56G/64G bit/s MUX MP1861A

Model/Order No.	Name
<b>Main Frame</b>	
MP1861A	56G/64G bit/s MUX
<b>Standard Accessories</b>	
J1658A	Coaxial Skew Match Pair Cable (1.3 m, K Connector): 1 set
J1652A	Coaxial Cable (0.5 m, K Connector): 1 pc
J1654A	U Link Cable B: 1 pc
J1363A	Protection Cap: 2 pcs
41V-6	Precision Fixed Attenuator 6 dB: 2 pcs
J1632A	Terminator: 4 pcs
J1341A	Open: 3 pcs
J1655A	Semi-rigid Cable (0.2 m, V): 1 pc
J1475A	USB Cable: 1 pc
Z1312A	AC Adapter: 1 pc
G0342A	ESD Discharger: 1 pc
J0017	Power Cord, 2.5 m: 1 pc
Z0897A	MP1800A Manual CD: 1 pc
Z0918A	MX180000A Software CD: 1 pc
<b>Options</b>	
MP1861A-001	64G bit/s Extension
MP1861A-011	Variable Data Output (0.5 to 2.5 Vp-p)
MP1861A-013	Variable Data Output (0.5 to 3.5 Vp-p)
MP1861A-030	Variable Data Delay
<b>Retrofit Options</b>	
MP1861A-101	64G bit/s Extension Retrofit
MP1861A-111	Variable Data Output (0.5 to 2.5 Vp-p) Retrofit
MP1861A-113	Variable Data Output (0.5 to 3.5 Vp-p) Retrofit
MP1861A-130	Variable Data Delay Retrofit
<b>Optional Accessories</b>	
J1600A	Skew Match Pair Cable (0.2 m, V connector)
J1656A	Coaxial Cable Set (MP1861A – MP1862A)
J1646A	Passive Equalizer 6 dB (V connector)
<b>Maintenance Service</b>	
MP1861A-ES310	Three Years Extended Warranty Service
MP1861A-ES510	Five Years Extended Warranty Service

#### 56G/64G bit/s DEMUX MP1862A

Model/Order No.	Name
<b>Main Frame</b>	
MP1862A	56G/64G bit/s DEMUX
<b>Standard Accessories</b>	
J1657A	Coaxial Cable (1 m, K Connector): 2 pcs
J1668A	Coaxial Cable (0.8 m, K connector): 1 pc
J1654A	U Link Cable B: 1 pc
J1363A	Protection Cap: 2 pcs
41V-6	Precision Fixed Attenuator 6 dB: 2 pcs
J1632A	Terminator: 5 pcs
J1341A	Open: 1 pc
J1475A	USB Cable: 1 pc
Z1312A	AC Adapter: 1 pc
G0342A	ESD Discharger: 1 pc
J0017	Power Cord, 2.5 m: 1 pc
Z0897A	MP1800A Manual CD: 1 pc
Z0918A	MX180000A Software CD: 1 pc
<b>Options</b>	
MP1862A-001	64G bit/s Extension
<b>Retrofit Options</b>	
MP1862A-101	64G bit/s Extension Retrofit
<b>Optional Accessories</b>	
J1600A	Skew Match Pair Cable (0.2 m, V connector)
J1656A	Coaxial Cable Set (MP1861A – MP1862A)
J1646A	Passive Equalizer 6 dB (V connector)
<b>Maintenance Service</b>	
MP1862A-ES310	Three Years Extended Warranty Service
MP1862A-ES510	Five Years Extended Warranty Service

#### Data Signal Combiner MZ1854A

Model/Order No.	Name
<b>Main Frame</b>	
MZ1854A	Data Signal Combiner
<b>Standard Accessories</b>	
Z0897A	MP1800A Manual CD

#### Software

Model/Order No.	Name
MX181500A	Jitter/Noise Tolerance Test Software

## • United States

### Anritsu Company

1155 East Collins Blvd., Suite 100, Richardson,  
TX 75081, U.S.A.

Toll Free: 1-800-267-4878

Phone: +1-972-644-1777

Fax: +1-972-671-1877

## • Canada

### Anritsu Electronics Ltd.

700 Silver Seven Road, Suite 120, Kanata,  
Ontario K2V 1C3, Canada

Phone: +1-613-591-2003

Fax: +1-613-591-1006

## • Brazil

### Anritsu Eletronica Ltda.

Praça Amadeu Amaral, 27 - 1 Andar

01327-010 - Bela Vista - Sao Paulo - SP

Brazil

Phone: +55-11-3283-2511

Fax: +55-11-3288-6940

## • Mexico

### Anritsu Company, S.A. de C.V.

Av. Ejército Nacional No. 579 Piso 9, Col. Granada

11520 México, D.F., México

Phone: +52-55-1101-2370

Fax: +52-55-5254-3147

## • United Kingdom

### Anritsu EMEA Ltd.

200 Capability Green, Luton, Bedfordshire, LU1 3LU, U.K.

Phone: +44-1582-433200

Fax: +44-1582-731303

## • France

### Anritsu S.A.

12 avenue du Québec, Bâtiment Iris 1- Silic 612,

91140 VILLEBON SUR YVETTE, France

Phone: +33-1-60-92-15-50

Fax: +33-1-64-46-10-65

## • Germany

### Anritsu GmbH

Nemetschek Haus, Konrad-Zuse-Platz 1

81829 München, Germany

Phone: +49-89-442308-0

Fax: +49-89-442308-55

## • Italy

### Anritsu S.r.l.

Via Elio Vittorini 129, 00144 Roma, Italy

Phone: +39-6-509-9711

Fax: +39-6-502-2425

## • Sweden

### Anritsu AB

Kistagången 20B, 164 40 KISTA, Sweden

Phone: +46-8-534-707-00

Fax: +46-8-534-707-30

## • Finland

### Anritsu AB

Teknobulevardi 3-5, FI-01530 VANTAA, Finland

Phone: +358-20-741-8100

Fax: +358-20-741-8111

## • Denmark

### Anritsu A/S

Kay Fiskers Plads 9, 2300 Copenhagen S, Denmark

Phone: +45-7211-2200

Fax: +45-7211-2210

## • Russia

### Anritsu EMEA Ltd.

#### Representation Office in Russia

Tverskaya str. 16/2, bld. 1, 7th floor.

Moscow, 125009, Russia

Phone: +7-495-363-1694

Fax: +7-495-935-8962

## • Spain

### Anritsu EMEA Ltd.

#### Representation Office in Spain

Edificio Cuzco IV, Po. de la Castellana, 141, Pta. 8

28046, Madrid, Spain

Phone: +34-915-726-761

Fax: +34-915-726-621

## • United Arab Emirates

### Anritsu EMEA Ltd.

#### Dubai Liaison Office

902, Aurora Tower,

P O Box: 500311 - Dubai Internet City

Dubai, United Arab Emirates

Phone: +971-4-3758479

Fax: +971-4-4249036

## • India

### Anritsu India Private Limited

2nd & 3rd Floor, #837/1, Binnamangla 1st Stage,

Indiranagar, 100ft Road, Bangalore - 560038, India

Phone: +91-80-4058-1300

Fax: +91-80-4058-1301

## • Singapore

### Anritsu Pte. Ltd.

11 Chang Charn Road, #04-01, Shriro House

Singapore 159640

Phone: +65-6282-2400

Fax: +65-6282-2533

## • P.R. China (Shanghai)

### Anritsu (China) Co., Ltd.

Room 2701-2705, Tower A,

New Caohejing International Business Center

No. 391 Gui Ping Road Shanghai, 200233, P.R. China

Phone: +86-21-6237-0898

Fax: +86-21-6237-0899

## • P.R. China (Hong Kong)

### Anritsu Company Ltd.

Unit 1006-7, 10/F., Greenfield Tower, Concordia Plaza,

No. 1 Science Museum Road, Tsim Sha Tsui East,

Kowloon, Hong Kong, P.R. China

Phone: +852-2301-4980

Fax: +852-2301-3545

## • Japan

### Anritsu Corporation

8-5, Tamura-cho, Atsugi-shi, Kanagawa, 243-0016 Japan

Phone: +81-46-296-6509

Fax: +81-46-225-8359

## • Korea

### Anritsu Corporation, Ltd.

5FL, 235 Pangyoyeok-ro, Bundang-gu, Seongnam-si,

Gyeonggi-do, 13494 Korea

Phone: +82-31-696-7750

Fax: +82-31-696-7751

## • Australia

### Anritsu Pty. Ltd.

Unit 20, 21-35 Ricketts Road,

Mount Waverley, Victoria 3149, Australia

Phone: +61-3-9558-8177

Fax: +61-3-9558-8255

## • Taiwan

### Anritsu Company Inc.

7F, No. 316, Sec. 1, NeiHu Rd., Taipei 114, Taiwan

Phone: +886-2-8751-1816

Fax: +886-2-8751-1817